



AGENDA

REGULAR MEETING OF COUNCIL
Monday, September 9th, 2024 at 6:00 PM
IN THE CIVIC CENTRE COUNCIL CHAMBERS

Members of Council and the public may access the meeting, electronically, as follows:

Dial: 1-800-974-5902
Conference ID: 9076440

KINDLY TURN OFF ALL CELL PHONES FOR THE DURATION OF THE MEETING

1. CALL MEETING TO ORDER 6:00 p.m.

INDIGENOUS LAND ACKNOWLEDGEMENT

The Municipality of Chapleau is situated on the ancestral treaty and title lands of the Anishinabe and Cree peoples in the Treaty 9 area, and recognizes the neighbouring First Nations of Brunswick House, Chapleau Cree, Chapleau Ojibwe, Michipicoten and Missanabi Cree.

We acknowledge the long history of First Nations and Metis People in Ontario and show respect to them today.

2. APPROVAL OF AGENDA

3. DISCLOSURE OF PECUNIARY INTEREST

4. DELEGATIONS

5. COMMITTEE OF ADJUSTMENT – None

6. CONSENT AGENDA

Items listed under the Consent Agenda are considered routine and will be enacted in one motion. A member of Council may request one or more items to be removed from the Consent Agenda for separate discussion and/or Action.

6.1 Council and Committee Meeting Minutes

6.1.1 Regular Council Meeting Minutes for Monday, August 26, 2024

7. BUSINESS

- 7.1 New Snow Plow Blade for Airport – Report R. Raymond
- 7.2 SSCHS – Request for Handi-Transit service for Fall Fair
- 7.3 Hydro One Community BBQ Event – Tuesday September 17, 2024
- 7.4 Biomass Energy Project in Chapleau

8. ACCOUNTS PAYABLE

9. RESOLUTIONS - None

10. CORRESPONDENCE

- A. Township of Russell resolution to support AMCTO Provincial Updates to the Municipal Elections Act
- B. City of Orillia resolution regarding a request for the Province to support family physicians

11. IN CAMERA

- 11.1 In Camera Session Meeting Minutes for the Regular Council Meeting of June 10, 2024. *
- 11.2 Personal matters about an identifiable individual, including municipal or local board employees, pursuant to *Ontario Municipal Act, Section 239(2)(b)*
 - Human Resources (4 Items) *
- 11.3 A proposed or pending acquisition or disposition of land by the municipality or local board, pursuant to *Ontario Municipal Act, Section 239(2)(c)*
 - Potential Sale of Municipal Property

Matters Arising from In Camera Session

12. CONFIRMATORY BY-LAW

13. ADJOURNMENT

CONSENT AGENDA



REGULAR MEETING OF COUNCIL
MONDAY, AUGUST 26, 2024 at 5:30 PM
 IN THE CIVIC CENTRE COUNCIL CHAMBERS

Attendance:

Council: Mayor Ryan Bignucolo
 Deputy Mayor Lisi Bernier
 Councillor Cathy Ansara
 Councillor Alex Lambruschini
 Councillor Paul Bernier

Participated by Teleconference: Judith Meyntz, CAO

Staff: Réjean Raymond, Operations Director
 Carole Ouellette, Leisure & Cultural Services Manager
 Kim Jean, Executive Assistant

Guests: 0

Attendees: 5

1. CALL MEETING TO ORDER

THAT the Council of the Corporation of the Township of Chapleau does hereby call the Regular Council Meeting of Monday, August 26, 2024 to order at 5:30 p.m.

INDIGENOUS LAND ACKNOWLEDGEMENT

The Municipality of Chapleau is situated on the ancestral treaty and title lands of the Anishinabe and Cree peoples in the Treaty 9 area, and recognizes the neighbouring First Nations of Brunswick House, Chapleau Cree, Chapleau Ojibwe, Michipicoten and Missanabi Cree.

We acknowledge the long history of First Nations and Metis People in Ontario and show respect to them today.

2. APPROVAL OF AGENDA

RESOLUTION 13-195:

A. LAMBRUSCHINI – C. ANSARA

WHEREAS the Members of Council have been presented with an Agenda for the Regular Council Meeting of Monday, August 26, 2024;

BE IT RESOLVED THAT the Agenda be adopted as presented.

Carried.

3. DISCLOSURE OF PECUNIARY INTEREST

Mayor Bignucolo requested that any pecuniary interest be declared for the record.
None Declared.

4. DELEGATIONS: None

5. COMMITTEE OF ADJUSTMENT - None

**6. CONSENT AGENDA
RESOLUTION 13-196:
P. BERNIER – L. BERNIER**

WHEREAS the Council of the Township of Chapleau has reviewed the Consent Agenda consisting of:

- 6.1 Council and Committee Meeting Minutes
 - 6.1.1 Regular Council Meeting Minutes for Monday, July 22, 2024

NOW THEREFORE BE IT RESOLVED THAT the Council of the Township of Chapleau does hereby approve the Regular Council Meeting Minutes for Monday, July 22, 2024.

Carried.

**7. BUSINESS
RESOLUTION 13-197:
A. LAMBRUSCHINI – P. BERNIER**

- 7.1 Citizen concern regarding use of Jake Brakes and Speed Limit Sign

THAT the Council of the Township of Chapleau does receive for information the citizen's concern regarding speed limits within the township and use of Jake Brakes within town limits,

AND THAT Council directs the CAO to investigate these issues and provide a report to Council on suggested solutions to keep the roadways of Chapleau safe within town limits,

Carried.

**RESOLUTION 13-198:
L. BERNIER – C. ANSARA**

- 7.2 Housing-Enabling Water Treatment Grant Funding results from the Ministry of Infrastructure.

THAT the Council of the Township of Chapleau hereby receives the notification that the grant application for funding was unsuccessful.

AND FURTHERMORE, THAT the Township of Chapleau has been notified of another Housing-enabling Water Treatment Grant Funding being released shortly through the Provincial government;

AND THAT the Township of Chapleau intends to apply again for funding to improve our Water Treatment Plan water tanks.

Carried.

RESOLUTION 13-199:

P. BERNIER – C. ANSARA

- 7.3 National Truth and Reconciliation Event request by Maamwesying for a special fire permit and use of the Community Centre Hall for two days of celebrations.

THAT the Council of the Township of Chapleau does hereby approve the request of the Maamwesying for a one-time special fire permit on September 27, 2024,

AND THAT Council hereby approves waiving the Community Centre rental fee of 286.50 per day for a total of \$573.00 for both September 26 and 27, 2024.

Carried.

RESOLUTION 13-200:

A. LAMBRUSCHINI – L. BERNIER

- 7.4 Michael Mantha – Sexual harassment investigation concluded

THAT the Council of the Township of Chapleau hereby acknowledges the allegations of workplace harassment, sexual harassment, discrimination on the basis of sex, and abuse of authority and creation of a toxic workplace has all been substantiated through the investigation of Jasbir Parar, independent investigation;

AND THAT the Council of the Township of Chapleau does not condone this type of conduct in our places of business;

AND FURTHERMORE, THAT the Council does hereby direct the administration that we will no longer permit Micheal Mantha access to our places of business, nor permit him to rent space in our Civic Centre to conduct his business;

AND FURTHER Council directs the CAO to issue a letter advising the Office of Michael Mantha of this resolution.

Carried.

RESOLUTION 13-201:

P. BERNIER – A. LAMBRUSCHINI

- 7.5 Centre Culturel – Alliance des francophones engagés de Chapleau

THAT the Council of the Township of Chapleau does hereby approve the request of the Centre Culturel, on behalf of Alliance des francophones engages de

Chapleau, for permission to use the waterfront pavilion for *Journée des Franco-ontariens et Franco-ontariennes* and the anniversary of the franco-ontarien flag;

THAT the Council of the Township of Chapleau wishes to support the *Journée des Franco-ontariens et Franco-ontariennes* and the anniversary of the franco-ontarien flag ;

AND WHEREAS, the following Council Members wish to accept the invitation to attend the ceremony:

- Paul Bernier
- Cathy Ansara

Carried.

RESOLUTION 13-202:

B. ANSARA – L. BERNIER

7.6 CAO Report to Council

THAT the Council of the Township of Chapleau accepts the CAO Report for information.

Carried.

RESOLUTION 13-203:

C. ANSARA – P. BERNIER

7.7 2025 Taste of the North Carnival Report and Budget request

THAT the Council of the Township of Chapleau does hereby approve the Taste of the North Report and Budget request for 2025.

Carried.

8. ACCOUNTS PAYABLE

RESOLUTION 13-204:

L. BERNIER – C. ANSARA

THAT the Council of the Corporation of the Township of Chapleau does hereby receive for information the Accounts Payable listing in the amount of \$433,843.10 for the period ending August 20, 2024.

Carried.

9. RESOLUTIONS

RESOLUTION 13-205:

P. BERNIER – A. LAMBRUSCHINI

9.1 By-Law 2024-28 – Being a By-Law to authorize the Mayor and CAO to execute an agreement between the Ministry of Community Safety and Correctional Services Ontario Provincial Policy, Superior East – Chapleau Detachment and the Township of Chapleau.

THAT By-law Number 2024-28, Being a By-Law to authorize the Mayor and CAO

to execute an agreement between the Ministry of Community Safety and Correctional Services Ontario Provincial Policy, Superior East – Chapleau Detachment and the Township of Chapleau be read a first and second time on this day 26th of August, 2024;

AND FURTHER be Read a third time, passed and properly signed and sealed this 26th day of August, 2024.

Carried.

RESOLUTION 13-206:

L. BERNIER – A. LAMBRUSCHINI

9.2 By-Law 2024-29 - Being a By-Law to regulate the use of Body Worn Camera (BWC) and Access to Digital Recordings.

THAT By-law Number 2024-29, Being a By-Law to regulate the use of Body Worn Camera (BWC) and Access to Digital Recordings be read a first and second time on this day 26th of August, 2024;

AND FURTHER be Read a third time, passed and properly signed and sealed this 26th day of August, 2024.

Carried.

10. CORRESPONDENCE:

RESOLUTION 13-207:

P. BERNIER – C. ANSARA

THAT the Council of the Township of Chapleau receives the Correspondence from the August 26th, 2024 Council Agenda with no items extracted for discussion.

Carried.

11. IN CAMERA:

RESOLUTION 13-208:

P. BERNIER – A. LAMBRUSCHINI

Adjourn to In Camera Session

THAT the Corporation of the Council of the Township of Chapleau move into In Camera Session on Monday, August 26, 2024 at 5:43 p.m. for the following matters:

- 11.1 Personal matters about an identifiable individual, including municipal or local board employees, pursuant to *Ontario Municipal Act, Section 239(2)(b)*
- Human Resources (1 Items)

Carried.

Reconvene to Regular Meeting

RESOLUTION 13-209:

L. BERNIER – P. BERNIER

THAT this meeting be reconvened to a Regular Meeting at 6:07 p.m.

Carried.

**12. CONFIRMATORY BY-LAW
RESOLUTION 13-210:
P. BERNIER – A. LAMBRUSCHINI**

THAT By-law No. 2024-30, being a confirmatory by-law for the Regular Council Meeting of Monday, August 26, 2024 be given a First, Second, Third and final reading and is passed as of this date.

Carried.

**13. ADJOURNMENT
RESOLUTION 13-211:
P. BERNIER – C. ANSARA**

WHEREAS the business of the Meeting has concluded:

NOW THEREFORE BE IT RESOLVED THAT this meeting be adjourned at 6.08 p.m. until the Regular Council meeting of Monday, September 9th, 2024 at 6:00 p.m. or the call of the Chair.

Carried.

Ryan Bignucolo Mayor

Judith Meyntz CAO

BUSINESS

OFFICE OF THE OPERATIONS DIRECTOR

September 5, 2024

Memorandum**To:** Mayor Bignucolo and Members of Council**From:** Réjean Raymond, Operations Director**Re:** Recommendation to purchase a snowplow blade system for the Chapleau Airport.

Dear Mayor Bignucolo and Members of Council:

Request

To consider purchasing a snowplow blade to replace the existing one-way snowplow and wings system at the Chapleau Airport.

Background

The existing one-way snowplow and wing system require two staffs to connect and disconnect the wing as per the manufacturer. We only have one staff working at the airport and connecting and disconnecting the wings alone is not safe.

During the budget process, it was decided to purchase a new snowplow blade system for the airport and the old one-way will be transferred to the Chapleau landfill to be used to plow and the wing will remain in storage as it is not needed.

The 2024 budget was approved with an amount of \$50,000.00 to purchase the new snowplow system.

Pricing request process

Six companies were invited to submit pricing.

We have received a total of three companies that provided pricing for the airport snow blade before the deadline.

One came in a day later and was not retained.

The following is the information that was sent to the six companies.

The Township of Chapleau is requesting pricing for a Reactor blade 4-IN-1 ANGLE BLADE (5 FT. WING) 6205 with fluid edges made by AMI Model number SB6251222FE 12 feet closed / 22 feet open or the equivalent.

The blade must be compatible with our Craig quick attach. See attached picture of the model number of the coupler on the loader and the two pictures showing the attachment on the bucket.

The John Deere 644 loader already has hydraulic plumbing on the main boom. It is the responsibility of your company to schedule a site visit to confirm what you will need to connect the blade. Please contact Sam St.

Amand at s.stamand@chapleau.ca or by calling 705-870-1334 to schedule an appointment.

Pricing to be submitted as follows:

1. Pricing for a complete blade Model number SB6251222FE 12 feet closed / 22 feet open with Craig attachment to be delivered at the Chapleau Airport.
2. One extra full set of fluid edge cutting edge for the main blade and one set for both wings to be delivered at the Chapleau Airport.
3. Labour to install and connect the blade on the John Deere 644 at the Chapleau Airport.
4. Provide an expected date of delivery

Please email your quote to rraymond@chapleau.ca no later than 10 a.m. August 26, 2024.

Here is the list of the pricing received.

	2024 Airport Plow				2024 approved budget
	Timmins Mechanical Solutions Timmins Ontario	Toromont Cat Timmins Ontario	Toromont Cat Timmins Ontario	SMS Equipment Timmins Ontario	
Airport AMI 4 in 1 blade	\$ 44,717.50	\$ 36,987.75	\$ 52,960.00	\$ 42,800.30	\$50,000.00
SubTotal	\$ 44,717.50	\$ 36,987.75	\$ 52,960.00	\$ 42,800.30	
HST	\$ 5,813.28	\$ 4,808.41	\$ 6,884.80	\$ 5,564.04	
Total	\$ 50,530.78	\$ 41,796.16	\$ 59,844.80	\$ 48,364.34	
Please note that Toromont Cat did not provide all the pricing requested. Delivery, installation and a set of spare cutting edges was not included in their pricing sheet.					
Please note that SMS Equipment quote does not included fitting, hoses and electrical parts.					

Recommendation

Staff recommends to go with Timmins Mechanical Solutions Inc since their quote included everything required in the amount of \$44,717.50 + HST. The two other suppliers did not include all the cost related to the installation and there will be extra charges that will drive the cost higher.

Sincerely,



Réjean Raymond



Timmins Mechanical Solutions Inc. QUOTE

4539 HWY 101 WEST
Timmins, Ontario P4R 0E3
Canada

Quote No.: 7934
Date: 13-08-2024
Page: 1
Ship Date:

Sold To:

Township of Chapleau

-for quoting-
20 Pine St W
PO Box 129
Chapleau, ON P0M 1K0

Ship To:

Township of Chapleau
-for quoting-
20 Pine St W
PO Box 129
Chapleau, ON P0M 1K0

Business No.: 808133524

Item No.	Quantity	Unit	Description	Tax	Unit Price	Amount
			AMI 4 in 1 Blade			
SB621222FE2	1	Each	4 in 1 Blade (5 foot wing with fluid edge)	H	37,762.50	37,762.50
LP-102211H5	10	Each	Fluid Edge Segment Hardox 500	H	165.00	1,650.00
LP-102378H5	1	Each	Left End Fluid Edge Segement Hardox 500	H	246.25	246.25
LP-102377H5	1	Each	Right end Fluid Edge Segement Hardox 500	H	246.25	246.25
LP-102097	1	Each	Right floating Edge Assembly	H	571.25	571.25
LP-102098	1	Each	Left Floating Edge Assembly	H	571.25	571.25
Labour (Field)	14	Hour	Labour to travel to chapleau and perform instalation, included prep work in Timmins	H	180.00	2,520.00
Parts	1	lot	Hoses, fittings and electrical required for instalation	H	1,150.00	1,150.00
			All parts are 5 business days Freight of blade to chapleau included			
			Subtotal:			44,717.50
			H - HST 13%			
			HST			5,813.27
Shipped by						
Comments	VALID FOR 30 DAYS.A 3% fee will apply all Visa/MC transactions. Parts restocking fees may apply				Total Amount	50,530.77
Sold By:	Dion, Eric					



Quote 415134-01

Aug 20, 2024

TOWN OF CHAPLEAU

PO BOX 129
20 PINE STREET
CHAPLEAU
Ontario
P0M 1K0

Attention: REJEAN RAYMOND

We would like to thank you for your interest in our company and our products, and are pleased to quote the following for your consideration.

4-In-1 Blade (5 Foot Wing With Fluid Edge) SB621222FE2 C/W Electric Diverter

Stock Number: TBD

We wish to thank you for the opportunity of quoting on your equipment needs. Prices are subject to change at any time. If there are any questions, please do not hesitate to contact me.

Sincerely,

Shaun Hamelin,

Product Support Sales Representative

4-In-1 Blade (5 Foot Wing With FluidEdge) SB621222FE2 C/W Electric Divertor



PH: 1-800-556-9452
www.amiatattachments.com

**IT'S NOT A JOB
IT'S A PERFORMANCE**

SPECIFICATIONS:
 -35° BLADE ANGLE LEFT AND RIGHT WITH CROSS-OVER
 RELIEF VALVE PROTECTION
 -FLEXIBLE FLUID EDGE SEGMENTED CUTTING EDGE
 -MAXIMUM HYDRAULIC PRESSURE OF 3000 PSI
 -SINGLE BI-DIRECTIONAL AUXILIARY PORT REQUIRED
 -ELECTRICAL DIVERTER VALVE CONTROLS BLADE AND
 WINGS INDEPENDENTLY

AMI ATTACHMENTS SPECIFICATION DRAWING
 WHEEL LOADER 3.25-6.25 CU. YDS CAPACITY (CAT. 175-250)
 4-IN-1 BLADE 6205FE2



Part #	Retracted Width (A)	Extended Width (B)	Overall Road Width (Angled) (In.)	Height	Weight (lbs)
	ft	ft	In	In	In
SB621020FE2	10'	20'	115	53	5050
SB621222FE2	12'	22'	135	53	5375
SB621424FE2	14'	24'	155	53	5645
SB621626FE2	16'	26'	175	53	6100
SB621828FE2	18'	28'	195	53	6470
SB622030FE2	20'	30'	215	53	6835

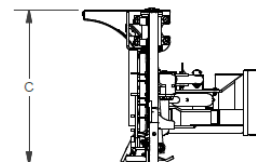
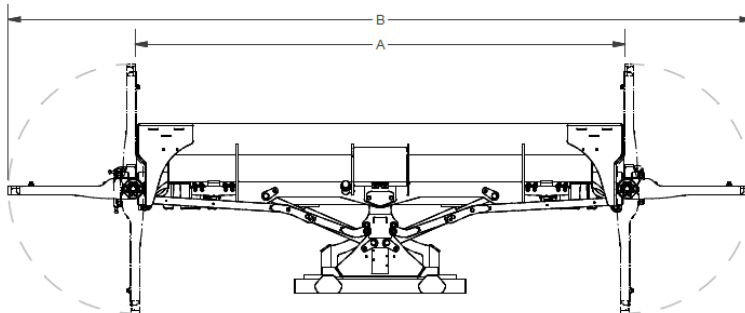

Other Components

Description

MEDIUM WHEEL LOADER WORK TOOLS

PLEASE USE THE 0P REFERENCE NUMBER LISTED ABOVE WHEN ORDERING

AMI 4 in 1 Blade with spare Fluid edge kit

Price: (plus applicable taxes)

Sell Price (Ex Works Timmins Branch)	\$36,987.75
Customer Credit	As described below
Grand Total	\$36,987.75

Warranty

Standard Warranty: Supplier 2 year limited Warranty

Customer Credit

Customer Credit: Customer Credit for Future Business

Additional Considerations

- This quote is based on a US to Cdn. Dollar exchange rate of (insert applicable rate). Any fluctuation in this rate at the time of order will adjust the price up or down as required.
- Rates can also be locked with a firm order.
- All Prices shown are taxes extra.
- Sales Price subject to Manufacturer Price Changes
- 1 to 2 week delivery from time of order
- FOB Timmins



Quote 415479-01

Aug 20, 2024

TOWN OF CHAPLEAU

PO BOX 129
20 PINE STREET
CHAPLEAU
Ontario
P0M 1K0

Attention: REJEAN RAYMOND

We would like to thank you for your interest in our company and our products, and are pleased to quote the following for your consideration.

Pless Maxx Pro

We wish to thank you for the opportunity of quoting on your equipment needs. Prices are subject to change at any time. If there are any questions, please do not hesitate to contact me.

Sincerely,

Shaun Hamelin,

Product Support Sales Representative

Other Components

Description

MEDIUM WHEEL LOADER WORK TOOLS

PLEASE USE THE 0P REFERENCE NUMBER LISTED ABOVE WHEN ORDERING

METAL PLESS MAXXPRO LIVE EDGE

Maxxpro Liveedge
Plowmaxx LD 200 Attach
DVDE3 Rexroth 24V(24GPM) (2 Button Box)
Attached Craig Acs Style 100-200
Spare set of Carbide cutting Edges $\frac{3}{4}$ "x6



Price: (plus applicable taxes)

Sell Price (Ex Works Timmins Branch)	\$52,960.00
Customer Credit	As described below
Grand Total	\$52,960.00

Warranty

Standard Warranty: 12 months complete

Customer Credit

Customer Credit: Customer Credit for Future Business

Additional Considerations

- This quote is based on a US to Cdn. Dollar exchange rate of (insert applicable rate). Any fluctuation in this rate at the time of order will adjust the price up or down as required.
- Rates can also be locked with a firm order.
- All Prices shown are taxes extra.
- Sales Price subject to Manufacturer Price Changes
- FOB Timmins



Our people define us

**4088 Highway 101 West
Timmins, Ontario P4R 0E6**

ATTACHMENT QUOTE SHEET
TOWNSHIP OF CHAPLEAU - 4-in-1 SNOWBLADE

Date: August 16 2024
Cell: 705-262-1939
Contact: Brenden Bouvier

Customer	Customer Contact	Phone
Twshp Of Chapleau	Rajeon Raymond	705-864-1330 EXT 228

Quantity	Part Number	Description	Price	Discount	Discount %	Total
1	SB621222FE2	4-In-1 Blade (5ft Wing With Fluid Edge)	\$34,804.20	Applied	Applied	\$34,804.20
		Complete with Divertor valve				
		Retracted W 12' , Extended W 22' , Height 53"				
		WLQT Quick Attach Lugging				
	LASB1250FACS1000Q	600 Series Snow Blade W Mouldboard Float Option				
	SBWKTS	Standard 3 Way Toggle				
10	LP-102211H5	Fluid Edge Segment- Hardox 500	\$1,504.80	Applied	Applied	\$1,504.80
1	LP-102378H5	Left End Fluid Edge Segment - Hardox 500	\$224.65	Applied	Applied	\$224.65
1	LP-102377H5	Right End Fluid Edge Segment - Hardox 500	\$224.65	Applied	Applied	\$224.65
1	LP-102097	Right Floating Edge Assy SB6205W Snowblade	\$521.00	Applied	Applied	\$521.00
1	LP-102098	Left Floating Edge Assy SB6205W Snowblade	\$521.00	Applied	Applied	\$521.00
1	Install	Service Tech Installation of Plow	-	Applied	Applied	-
1	Freight	Freight	\$2,500.00	Applied	Applied	\$ 2,500.00
		F.O.B Township Of Chapleau				
		Chapleau Airport				
					Totals	\$40,300.30

NOTE Prices do not include applicable taxes.
 Prices in effect for (30) thirty days.
 Freight is subject to change based on fuel costs
 Install subject to change if Tech needs lodging
 Machining Extra if required.

Subtotal	\$40,300.30
Labour	\$ 2,500.00
Travel	
Misc	
Total	\$42,800.30

**Please indicate your approval to
complete the above quote**

Signature: _____

Date: _____

Purchase Order Number: _____



Service de santé Chapleau Health Services
P.O Box 767
Chapleau, ON P0M 1K0
August 30th, 2024

Township of Chapleau
20 Pine ST. W. P.O. Box 129
Chapleau ON P0M 1K0
RE: Fall Fair

Dear Township of Chapleau,

On behalf of the Recreation Department of the Long Term Care Bignucolo Residence, we would like to request the services of the Handi-Transit Bus for the Fall Fair.

We would like the Handi-Transit Bus to be available for Friday, October 18th and Saturday, October 19th, 2024. The Residents thoroughly enjoyed this event last year and appreciated the availability of the Handi-Transit Bus. We kindly ask that the Township and Council consider donating the services to our Bignucolo Residents.

We thank you for your time, and your consideration.

Sincerely,

Louise Gaudreau

Recreation/Adult Day Program Coordinator
Chapleau Health Services
lgaudreau@sschs.ca
705-864-1520 ext 3062

18-009-24 Press Release for GMF and Gov. of Canada Review

Chapleau, ON September 5, 2024 – The Township of Chapleau is proud to be taking a step to be a part of the clean energy revolution. Chapleau is initiating the Chapleau District Heating Project, in partnership with Commercial BioEnergy Inc., a Northern Ontario biomass energy company dedicated to assisting communities in reducing their dependence on fossil fuels. The Chapleau District Heating Project will determine the feasibility of constructing a centralized biomass fuelled heating plant to deliver heating to potentially seven public buildings within the community. This will involve converting existing heating sources from propane or electricity to biomass generated heat, using locally sourced wood chips.

This innovative project will be the first project in North America of this scale. “Chapleau is very excited about the project. The Chapleau District Heating Project has the potential to pave the way for alternative heating sources for the community. Not only will the project reduce our carbon footprint and energy costs; but also, it will be creating job opportunities and contributing to sustainable economic development through the use of locally sourced wood products.” Said Chapleau’s Mayor Ryan Bignucolo.

Bignucolo added that, “the Chapleau Project anticipates a reduction in greenhouse gas emissions of up to 90% for all targeted buildings combined. That’s huge and in addition to a significant step towards positive efforts to mitigate climate change, it provides our community the beginning of true energy security and self-reliance.”

Chapleau CAO Judith Meyntz stated, “There are many great aspects to this project, but one that is particularly exciting for us as a forestry community is the dependency on using our wood chips for the heat plant. It creates the opportunity for the wood co-products to be used from our local mill.”

When asked about the project, Robert Manseau, President of Commercial BioEnergy Inc. stated, “We are proud to be partnering with Chapleau on this significant project. This project will demonstrate the viability of biomass as an alternative to fossil fuels, which is critical for rural communities like Chapleau, and remote communities; and provide support to the area’s forest industry in consuming surplus wood chips. These Northern communities are bound by fossil fuels dependency and their high costs.”

The Chapleau District Heating Project is currently in the feasibility phase which will determine the potential for the project’s implementation in 2026. The feasibility study will include a community consultation and stakeholder engagement process, which the project team anticipates beginning soon. For more information regarding the Chapleau District Heating Project, please contact:

Nadia Piccotti
Commercial BioEnergy Inc.
nadia@commercialbioenergy.ca

Ryan Bignucollo
Mayor of the Township of Chapleau
705-864-5050

This project is being made possible with financial assistance from the Green Municipal Fund, a Fund financed by the Government of Canada and administered by the Federation of Canadian Municipalities. For more information on the Green Municipal Fund and their goal of helping Canadian municipalities becoming resilient, net-zero communities please visit greenmunicipalfund.ca

ACCOUNTS PAYABLE

TOWNSHIP OF CHAPLEAU

COUNCIL CHEQUE REGISTER

Ck No.	Ck Date	Vendor Name	Invoice Description	Amount
12881	4-Sep-24	RECEIVER GENERAL - PAYROLL	REMITTANCE LIBRARY AUGUST	\$ 736.21
12882	4-Sep-24	RECEIVER GENERAL - PAYROLL	REMITTANCE AUGUST 16-31	\$ 18,127.62
12883	4-Sep-24	BELL CANADA	PHONE SEPTEMBER FIRE DEPT PAGING SYSTEM	\$ 46.50
12883	4-Sep-24	BELL CANADA	PHONE SEPTEMBER FIRE DEPT. HALL	\$ 46.50
12883	4-Sep-24	BELL CANADA	PHONE SEPTEMBER LIBRARY	\$ 58.93
12883	4-Sep-24	BELL CANADA	PHONE SEPTEMBER AIRPORT	\$ 58.93
12883	4-Sep-24	BELL CANADA	PHONE SEPTEMBER PW GARAGE	\$ 62.35
12883	4-Sep-24	BELL CANADA	PHONE SEPTEMBER ARENA	\$ 62.55
12883	4-Sep-24	BELL CANADA	PHONE SEPTEMBER CIVIC CENTRE	\$ 320.45
12883	4-Sep-24	BELL CANADA	PHONE SEPTEMBER EMERG. NO.	\$ 426.14
12884	4-Sep-24	BIDOUS MECHANICALSERVICES	REPAIRS GRADER/PUMPER 3/ZAMBONI/FUEL TRUCK	\$ 1,483.13
12885	4-Sep-24	BMO NESBITT BURNS	2023 CEMETERY PERPETUAL CARE TRUST CONTRIBUTION	\$ 2,740.00
12886	4-Sep-24	BRANDT	CUTTING EDGES & HARDWARE	\$ 2,376.46
12887	4-Sep-24	CANADIAN UNION OF PUBLIC EMPLOYEES	UNION DUES AUGUST	\$ 1,288.31
12888	4-Sep-24	CHAPLEAU AUTO PARTS	HAND SANITIZER	\$ 4.52
12888	4-Sep-24	CHAPLEAU AUTO PARTS	BIT	\$ 5.64
12888	4-Sep-24	CHAPLEAU AUTO PARTS	WIRE PIPE BRUSH	\$ 6.72
12888	4-Sep-24	CHAPLEAU AUTO PARTS	1 - WATER BOTTLE REFILL	\$ 9.95
12888	4-Sep-24	CHAPLEAU AUTO PARTS	BRAKE FLUID	\$ 11.04
12888	4-Sep-24	CHAPLEAU AUTO PARTS	2 - WATER BOTTLE REFILLS	\$ 19.90
12888	4-Sep-24	CHAPLEAU AUTO PARTS	2 - WATER BOTTLE REFILLS	\$ 19.90
12888	4-Sep-24	CHAPLEAU AUTO PARTS	WD40/SILICONE LUBE	\$ 23.37
12888	4-Sep-24	CHAPLEAU AUTO PARTS	ANTI-VIBRATION GLOVES	\$ 24.80
12888	4-Sep-24	CHAPLEAU AUTO PARTS	SHACKLE ANCHOR	\$ 24.81
12888	4-Sep-24	CHAPLEAU AUTO PARTS	CREMATION BOX CLEANING SUPPLIES	\$ 25.97
12888	4-Sep-24	CHAPLEAU AUTO PARTS	T-SHIRT WIPERS/ORANGE HAND CLEANER	\$ 26.76
12888	4-Sep-24	CHAPLEAU AUTO PARTS	EXCHANGE BEACON FIRE DEPT.	\$ 27.12
12888	4-Sep-24	CHAPLEAU AUTO PARTS	GLOVES	\$ 33.73
12888	4-Sep-24	CHAPLEAU AUTO PARTS	NOZZLE SET	\$ 34.97
12888	4-Sep-24	CHAPLEAU AUTO PARTS	MOTOMIX 50/50 4L	\$ 45.14
12888	4-Sep-24	CHAPLEAU AUTO PARTS	HEX SET/LIGHTING PRODUCT	\$ 48.67
12888	4-Sep-24	CHAPLEAU AUTO PARTS	AIR CHUCK/ AIR ADAPTOR	\$ 51.26
12888	4-Sep-24	CHAPLEAU AUTO PARTS	EAR PLUGS	\$ 60.23
12888	4-Sep-24	CHAPLEAU AUTO PARTS	5W-30 OIL	\$ 72.81
12888	4-Sep-24	CHAPLEAU AUTO PARTS	LIMIT STOP KIT/CHIESEL BALDE	\$ 94.81
12888	4-Sep-24	CHAPLEAU AUTO PARTS	OIL & FILTERS ZAMBONI	\$ 127.02
12888	4-Sep-24	CHAPLEAU AUTO PARTS	BEACON - 2500 CHEVY	\$ 138.01
12888	4-Sep-24	CHAPLEAU AUTO PARTS	RAIN JACKET/PANTS	\$ 338.83
12888	4-Sep-24	CHAPLEAU AUTO PARTS	BEACON AMBER - PUMPER 3	\$ 469.97
12888	4-Sep-24	CHAPLEAU AUTO PARTS	2- SPLASH PAD - DECHLORINATION PUCKS	\$ 779.59
12889	4-Sep-24	CHAPLEAU EXPRESS	CANADA DAY - HUGE SHOUT OUT TO SPONSORS	\$ 33.90
12889	4-Sep-24	CHAPLEAU EXPRESS	ADVERTISE NOTICE TO TAX PAYER	\$ 33.90
12889	4-Sep-24	CHAPLEAU EXPRESS	ADVERTISE CROSSING GUARD	\$ 33.90
12890	4-Sep-24	CHARLES W COLLINS STORES LIMITED	RETURN MICROWAVE	\$ (126.10)
12890	4-Sep-24	CHARLES W COLLINS STORES LIMITED	WOOL ICE MAKING	\$ 7.62
12890	4-Sep-24	CHARLES W COLLINS STORES LIMITED	WALLDRILLERS	\$ 8.05
12890	4-Sep-24	CHARLES W COLLINS STORES LIMITED	BUG REPELLENT	\$ 13.21
12890	4-Sep-24	CHARLES W COLLINS STORES LIMITED	FOAM SEALANT	\$ 13.94
12890	4-Sep-24	CHARLES W COLLINS STORES LIMITED	FOAM SEALANT	\$ 13.94
12890	4-Sep-24	CHARLES W COLLINS STORES LIMITED	CLEANER	\$ 16.09
12890	4-Sep-24	CHARLES W COLLINS STORES LIMITED	SURVEYOR TAPE/ SOAP	\$ 19.58
12890	4-Sep-24	CHARLES W COLLINS STORES LIMITED	SCREWS	\$ 20.93
12890	4-Sep-24	CHARLES W COLLINS STORES LIMITED	STRIPPING WHEEL/BRUSH	\$ 29.47
12890	4-Sep-24	CHARLES W COLLINS STORES LIMITED	CONNECTORS	\$ 30.05
12890	4-Sep-24	CHARLES W COLLINS STORES LIMITED	ROLLER	\$ 32.52
12890	4-Sep-24	CHARLES W COLLINS STORES LIMITED	SUNBLOCK	\$ 36.48
12890	4-Sep-24	CHARLES W COLLINS STORES LIMITED	SWIFFER DUSTER/GARBAGE BAGS	\$ 36.69
12890	4-Sep-24	CHARLES W COLLINS STORES LIMITED	PAINT	\$ 38.39
12890	4-Sep-24	CHARLES W COLLINS STORES LIMITED	SAND MIX & NAILS	\$ 40.53
12890	4-Sep-24	CHARLES W COLLINS STORES LIMITED	WALKWAY REPAIR	\$ 42.87

TOWNSHIP OF CHAPLEAU

COUNCIL CHEQUE REGISTER

Ck No.	Ck Date	Vendor Name	Invoice Description	Amount
12890	4-Sep-24	CHARLES W COLLINS STORES LIMITED	SPRAY BOTTLES/GARBAGE BAGS	\$ 49.79
12890	4-Sep-24	CHARLES W COLLINS STORES LIMITED	WW SUPPLIES - 10 TEAK ST.	\$ 55.79
12890	4-Sep-24	CHARLES W COLLINS STORES LIMITED	ROLLERS/LINERS/PAINT	\$ 72.84
12890	4-Sep-24	CHARLES W COLLINS STORES LIMITED	CABLE - 10 TEAK ST	\$ 90.51
12890	4-Sep-24	CHARLES W COLLINS STORES LIMITED	PAINT SUPPLIES	\$ 123.75
12890	4-Sep-24	CHARLES W COLLINS STORES LIMITED	MICROWAVE	\$ 126.10
12890	4-Sep-24	CHARLES W COLLINS STORES LIMITED	MICROWAVE	\$ 126.10
12890	4-Sep-24	CHARLES W COLLINS STORES LIMITED	FILTERS	\$ 163.88
12890	4-Sep-24	CHARLES W COLLINS STORES LIMITED	MOP/GARBAGE BAGS/PAPER TOWELS	\$ 164.74
12890	4-Sep-24	CHARLES W COLLINS STORES LIMITED	TOILET PAPER/PAPER TOWELS & GARBAGE BAGS	\$ 221.86
12890	4-Sep-24	CHARLES W COLLINS STORES LIMITED	ROAD LINE PAINT	\$ 488.13
12891	4-Sep-24	DONALD L DAVISON FUELS LTD	20,040L - JET A1	\$ 32,645.77
12892	4-Sep-24	ESRI CANADA	ANNUAL GIS SUBSCRIPTION	\$ 2,768.50
12893	4-Sep-24	FIASCHEITTI, STEWART CHRISTOPHER	PAYMENT ERROR REFUND	\$ 716.00
12894	4-Sep-24	GRA-HAM ENERGY LIMITED	REV. 9,793.7L 100LL	\$ (22,133.76)
12894	4-Sep-24	GRA-HAM ENERGY LIMITED	HST CREDIT 100LL JUNE 18TH	\$ (2,877.39)
12894	4-Sep-24	GRA-HAM ENERGY LIMITED	HST 100LL DELIVERY JUNE 18TH	\$ 3,819.40
12894	4-Sep-24	GRA-HAM ENERGY LIMITED	6,008.7L JET A1	\$ 11,067.42
12894	4-Sep-24	GRA-HAM ENERGY LIMITED	13,000L - 100LL	\$ 29,380.00
12894	4-Sep-24	GRA-HAM ENERGY LIMITED	19,910.1L JET A1	\$ 36,672.41
12894	4-Sep-24	GRA-HAM ENERGY LIMITED	13,967L 100LL	\$ 36,773.71
12895	4-Sep-24	JET ICE LIMITED	PAINT ICE	\$ 2,376.15
12896	4-Sep-24	J & N SIGNS AND PHOTOGRAPHY	LOGO FOR PW TRUCK	\$ 87.96
12896	4-Sep-24	J & N SIGNS AND PHOTOGRAPHY	NO DIVING/LANDFILL NO TRAFFIC THROUGH	\$ 470.70
12897	4-Sep-24	K.R. MCADAM SERVICES	PROPERTY STANDARDS CUT & TRIM GRASS	\$ 700.60
12898	4-Sep-24	LAMBRUSCHINI, ALEX	AMO - TRAVEL ALEX	\$ 944.68
12899	4-Sep-24	MANITOULIN SUDBURY DSSAB	DSSAB & LAND AMBULANCE SEPTEMBER	\$ 17,874.51
12900	4-Sep-24	MEYNTZ, JUDITH	TRAVEL -HONI CLOSING DOCUMENTS	\$ 133.28
12901	4-Sep-24	MINISTER OF FINANCE EHT	EHT AUGUST	\$ 3,884.48
12902	4-Sep-24	MINISTRY OF FINANCE	CREDIT 2024 LSR OPP DETACHMENT APRIL-JUNE	\$ (1,179.71)
12902	4-Sep-24	MINISTRY OF FINANCE	OPP SERVICES JULY	\$ 42,123.00
12903	4-Sep-24	MORIN, ALAN	SAFETY SHIRTS - MORIN	\$ 58.74
12904	4-Sep-24	NORTHERN COMMUNICATION SERVICE	FIRE DISPATCH SEPTEMBER	\$ 449.68
12905	4-Sep-24	NORTHERN METERING SERVICES	REPLACE PSI PRESSURE GAUGE FUEL TRUCK	\$ 148.03
12906	4-Sep-24	O.M.E.R.S.	OMERS AUGUST	\$ 33,129.68
12907	4-Sep-24	ORKIN CANADA	PEST CONTROL LANDFILL	\$ 56.50
12907	4-Sep-24	ORKIN CANADA	PEST CONTROL AUGUST ARENA	\$ 117.25
12908	4-Sep-24	PUBLIC HEALTH SUDBURY & DISTRICTS	MUNICIPAL LEVY SEPTEMBER	\$ 10,656.41
12909	4-Sep-24	PUROLATOR INC	SHIPPING REALTAX	\$ 5.90
12909	4-Sep-24	PUROLATOR INC	SHIPPING CHARGES	\$ 19.28
12910	4-Sep-24	QUATTTRA SCS	3 - PORTABLE RADIOS & BATTERY FIRE DEPT.	\$ 2,152.28
12911	4-Sep-24	RAYMOND, REJEAN	AMAZON - NUMBERED LINED NOTE BOOK	\$ 39.48
12912	4-Sep-24	RBC ROYAL BANK VISA	AMO - CONFERENCE REFUND CAO	\$ (1,015.87)
12912	4-Sep-24	RBC ROYAL BANK VISA	VALU MART - COFFEE SUPPLIES	\$ 80.04
12912	4-Sep-24	RBC ROYAL BANK VISA	BOOKS LIBRARY	\$ 124.35
12912	4-Sep-24	RBC ROYAL BANK VISA	NORCAT - WHIMS & NEWMOUNT TRAINING	\$ 146.84
12912	4-Sep-24	RBC ROYAL BANK VISA	NORCAT - WHIMS & NEWMOUNT TRAINING	\$ 146.84
12912	4-Sep-24	RBC ROYAL BANK VISA	NORCAT - WHIMS & NEWMOUNT TRAINING	\$ 146.84
12912	4-Sep-24	RBC ROYAL BANK VISA	STARLINK -AUGUST AIRPORT	\$ 158.20
12912	4-Sep-24	RBC ROYAL BANK VISA	AMAZON - EMERGENCY SAFETY SHOWER STATION	\$ 268.09
12912	4-Sep-24	RBC ROYAL BANK VISA	ORFA - SAFE ARENA REFRIDGERATION PLANT	\$ 310.75
12912	4-Sep-24	RBC ROYAL BANK VISA	ORFA - REFRIDGERATION & ICE REFURFACE LOGBOOK	\$ 329.96
12912	4-Sep-24	RBC ROYAL BANK VISA	CANADA POST - 4 ROLLS STAMPS	\$ 447.48
12913	4-Sep-24	RBC ROYAL BANK VISA	AMAZON - BLEUTOOTH HEADSET	\$ 36.60
12913	4-Sep-24	RBC ROYAL BANK VISA	OWWCO - DW CERTIFICATE RENEWAL - TIM HOLMES	\$ 145.00
12913	4-Sep-24	RBC ROYAL BANK VISA	TSSA - 3 YEAR LICENSE	\$ 257.00
12913	4-Sep-24	RBC ROYAL BANK VISA	WEATHERTECH - FLOORLINER CHEVY	\$ 410.08
12914	4-Sep-24	SPECTRUM TELECOM GROUP LTD.	PW RADIO SEPTEMBER	\$ 49.72
12914	4-Sep-24	SPECTRUM TELECOM GROUP LTD.	GPS TRACKING SEPTEMBER	\$ 107.35
12915	4-Sep-24	TBAYTEL	CELL PHONES SEPTEMBER	\$ 345.41

TOWNSHIP OF CHAPLEAU**COUNCIL CHEQUE REGISTER**

Ck No.	Ck Date	Vendor Name	Invoice Description	Amount
12916	4-Sep-24	WEAVER SIMMONS LLP	LEGAL SERVICES	\$ 340.70
12916	4-Sep-24	WEAVER SIMMONS LLP	GENERAL LEGAL SERIVCES	\$ 711.90
12917	4-Sep-24	WORKPLACE SAFETY AND INSURANCE BOARD	WSIB AUGUST	\$ 6,259.65
12918	4-Sep-24	WSP CANADA GROUP LIMITED	FACILITIES ASSESMENT AIRPORT	\$ 53,587.98
12919	4-Sep-24	XEROX CANADA LTD.	COPIER CHARGES AUGUST	\$ 98.12
12919	4-Sep-24	XEROX CANADA LTD.	COPIER LEASE SEPTEMBER	\$ 267.66
				\$ 339,260.70

CORRESPONDENCE



TOWNSHIP OF
RUSSELL

CERTIFIED RESOLUTION

Date: **August 26, 2024** **Item(s) no.:** 10 (ref. a)

Subject: Resolution to Support AMCTO Provincial Updates to the Municipal Elections Act

Moved by: Jamie Laurin

Seconded by: Lisa Deacon

WHEREAS elections rules need to be clear, supporting candidates and voters in their electoral participation and election administrators in running elections; and

WHEREAS legislation needs to strike the right balance between providing clear rules and frameworks to ensure the integrity of the electoral process; and

WHEREAS the legislation must also reduce administrative and operational burden for municipal staff ensuring that local election administrators can run elections in a way that responds to the unique circumstances of their local communities; and

WHEREAS the Municipal Elections Act, 1996 (MEA) will be 30 years old by the next municipal and school board elections in 2026; and

WHEREAS the MEA sets out the rules for local elections, the Assessment Act, 1990 and the Education Act, 1990 also contain provisions impacting local elections adding more places for voters, candidates, and administrators to look for the rules that bind the local democratic process in Ontario; and

WHEREAS with rules across three pieces of legislation, and the MEA containing a patchwork of clauses, there are interpretation challenges, inconsistencies, and gaps to fill; and

WHEREAS the Act can pose difficulties for voters, candidates, contributors and third-party advertisers to read, to interpret, to comply with and for election administrators to enforce; and

WHEREAS while local elections are run as efficiently and effectively as can be within the current legislative framework, modernization and continuous improvement is needed to ensure the Act is responsive to today's needs and tomorrow's challenges; and

WHEREAS to keep public trust and improve safeguards the Act should be reviewed considering the ever-changing landscape which impacts elections administration including privacy, the threats of foreign interference, increased spread of mis/disinformation and the increased use of technologies like artificial intelligence and use of digital identities; and

WHEREAS the Association of Municipal Managers, Clerks, and Treasurers of Ontario (AMCTO) reviewed the Act and has provided several recommendations including modernizing the legislation, harmonizing rules, and streamlining and simplifying administration; and

WHEREAS AMCTO put forward recommendations for amendments ahead of the 2026 elections and longer-term recommendations for amendments ahead of the 2030 elections; therefore

BE IT RESOLVED THAT the Township of Russell calls for the Province to update the MEA with priority amendments as outlined by AMCTO before Summer 2025 and commence work to review and re-write the MEA with longer-term recommendations ahead of the 2030 elections; and be it further

RESOLVED that this resolution will be forwarded to all municipalities in Ontario for support and that each endorsement be then forwarded to the Minister of Municipal Affairs and Housing, the Minister of Education, the Minister of Public and Business Service Delivery, Minister of Finance, the Premier of Ontario, MPP of Glengarry-Prescott-Russell and AMCTO.

MOTION APPROVED

I, Joanne Camiré Laflamme, Clerk of the Corporation of the Township of Russell, hereby certify that the foregoing is a true copy of the resolution adopted by the Council of the Corporation of the Township of Russell on the 26th day of August 2024.



Joanne Camiré Laflamme
Clerk



CANTON DE
RUSSELL
RÉSOLUTION CERTIFIÉE

Date: 26 août 2024 **Article no.:** 10 (réf. a)

Objet: Résolution visant à soutenir les mises à jour provinciales de l'AMCTO concernant la loi sur les élections municipales

Proposé par : Jamie Laurin

Appuyé par: Lisa Deacon

Attendu que les règles électorales doivent être claires, qu'elles doivent aider les candidats et les électeurs à participer aux élections et les administrateurs électoraux à organiser les élections; et

Attendu que la législation doit trouver un juste équilibre entre la fourniture de règles et de cadres clairs pour garantir l'intégrité du processus électoral; et

Attendu que la législation doit également réduire le fardeau administratif et opérationnel pour le personnel municipal en veillant à ce que les administrateurs électoraux locaux puissent organiser les élections d'une manière qui réponde aux circonstances uniques de leurs communautés locales; et

Attendu que la Loi de 1996 sur les élections municipales (LEM) aura 30 ans au moment des prochaines élections municipales et scolaires en 2026; et

Attendu que la LEM établit les règles pour les élections locales, que la Loi de 1990 sur l'évaluation foncière et la Loi de 1990 sur l'éducation contiennent également des dispositions ayant une incidence sur les élections locales, ce qui augmente le nombre d'endroits où les électeurs, les candidats et les administrateurs doivent chercher les règles qui régissent le processus démocratique local en Ontario; et

Attendu qu'avec des règles réparties dans trois textes législatifs, et que la Loi sur l'éducation contient un ensemble de clauses disparates, il y a des problèmes d'interprétation, des incohérences et des lacunes à combler; et

Attendu que la loi peut poser des difficultés aux électeurs, aux candidats, aux donateurs et aux annonceurs tiers qui doivent la lire, l'interpréter, s'y conformer et aux administrateurs électoraux qui doivent l'appliquer; et

Attendu que si les élections locales sont gérées aussi efficacement que possible dans le cadre législatif actuel, une modernisation et une amélioration continue sont nécessaires pour garantir que la loi réponde aux besoins d'aujourd'hui et aux défis de demain; et

Attendu que pour conserver la confiance du public et améliorer les garanties, la loi devrait être révisée en tenant compte du paysage en constante évolution qui a une incidence sur l'administration des élections, y compris la protection de la vie privée, les menaces d'ingérence étrangère, la propagation accrue de la désinformation et l'utilisation accrue de technologies telles que l'intelligence artificielle et l'utilisation d'identités numériques; et

Attendu que « Association of Municipal Managers, Clerks, and Treasurers of Ontario » (AMCTO) a examiné la loi et a formulé plusieurs recommandations, notamment la modernisation de la législation, l'harmonisation des règles et la rationalisation et la simplification de l'administration; et

Attendu que AMCTO a formulé des recommandations de modifications avant les élections de 2026 et des recommandations de modifications à plus long terme avant les élections de 2030; par conséquent

Il est résolu que le canton de Russell demande à la province de mettre à jour la LEM avec les modifications prioritaires décrites par AMCTO avant l'été 2025 et de commencer à examiner et à réécrire la LEM avec des recommandations à plus long terme avant les élections de 2030; et qu'il soit en outre

Résolu que cette résolution soit transmise à toutes les municipalités de l'Ontario pour obtenir leur appui et que chaque appui soit ensuite transmis au ministre des Affaires municipales et du Logement, au ministre de l'Éducation, au ministre de la Prestation des services publics et commerciaux, au ministre des Finances, au premier ministre de l'Ontario, au député provincial de Glengarry-Prescott-Russell et à AMCTO.

MOTION ADOPTÉE

Je, Joanne Camiré Laflamme, greffière de la corporation du canton de Russell, atteste que la présente est une copie certifiée de la résolution adoptée par le conseil de la municipalité de Russell le 26^e jour d'août 2024.



Joanne Camiré Laflamme
Greffière



Office of the Mayor

 T: 705-325-2447
 F: 705-325-5178
 mayor@orillia.ca
 orillia.ca
 50 Andrew St. S., Suite 300,
 Orillia, ON L3V 7T5

August 30, 2024

Hon. Doug Ford
 Premier
 Premier's Office
 Room 281
 Legislative Building, Queen's Park
 Toronto, ON M7A 1A1

Dear Premier Ford:

Re: Resolution regarding a request for the Province to support family physicians

Orillia City Council at its meeting held August 12, 2024, adopted the following resolution:

"THAT, further to the correspondence dated July 31, 2024 from the City of Toronto regarding a resolution with respect to a request for the Province to support family physicians, the following supporting resolution be passed:

"BE IT RESOLVED THAT the Council for the Corporation of the City of Orillia hereby supports the resolution passed by the City of Toronto on June 26, 2024 with respect to a request for the Province to support family physicians;

AND FURTHER THAT a copy of this resolution be sent to the Honourable Doug Ford, Premier of Ontario; the Honourable Sylvia Jones, Minister of Health; the Honourable Jill Dunlop, Member of Provincial Parliament for Simcoe-North; the Association of Municipalities of Ontario; and all Ontario municipalities."

The above is for your consideration. If you require any additional information, please let me know.



Resolution regarding a request for the Province to support family physicians

August 30, 2024

Page 2 of 2

Sincerely,

A handwritten signature in black ink, appearing to read 'Don McIsaac'.

Don McIsaac
Mayor

DM:rb

Copy to: Honourable Sylvia Jones, Deputy Premier of Ontario
Honourable Jill Dunlop, Minister of Education, and Member of Provincial Parliament for
Simcoe-North
Association of Municipalities of Ontario
All Ontario Municipalities